

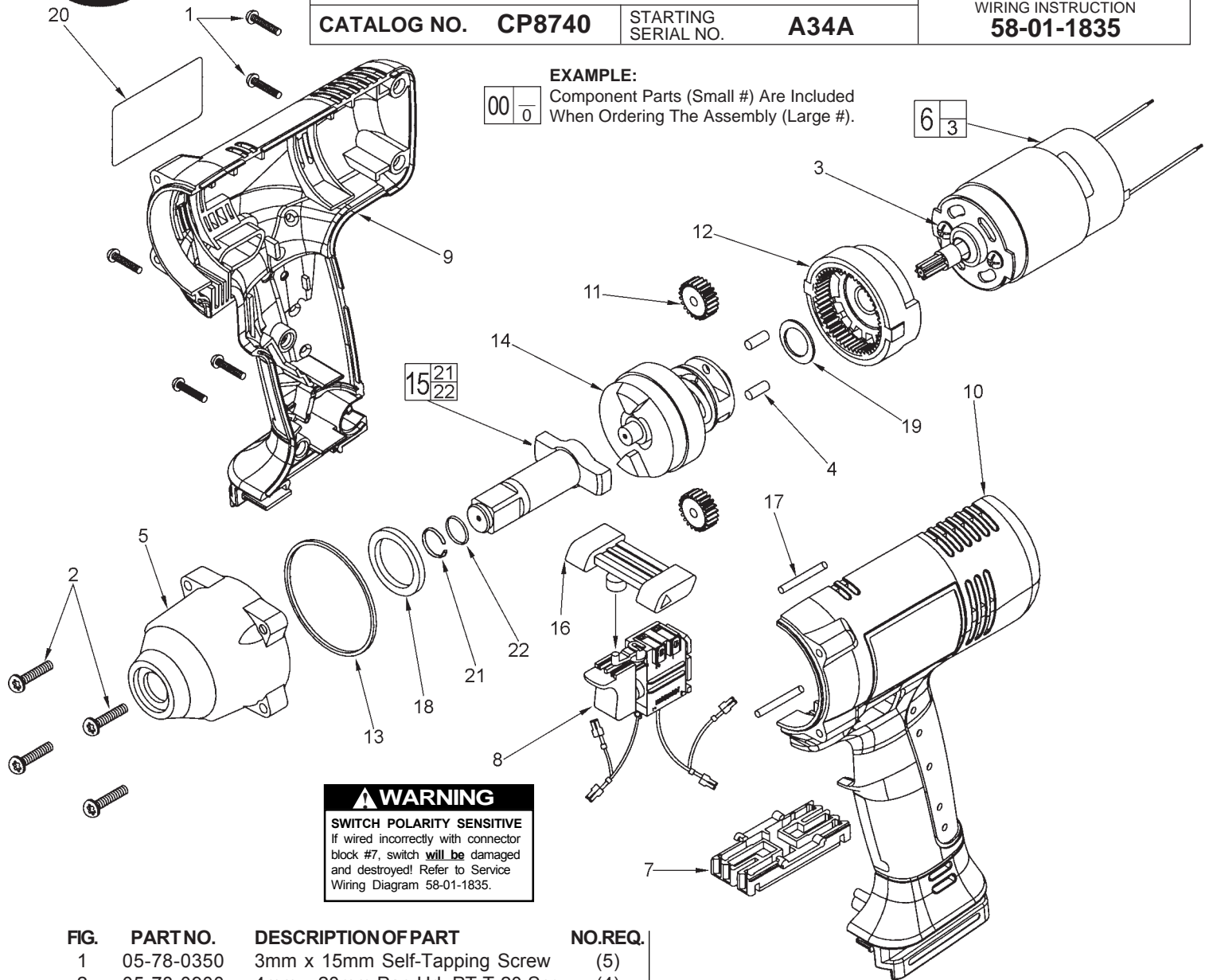

Chicago Pneumatic™ SERVICE PARTS LIST

BULLETIN NO.
54-26-2025

SPECIFY CATALOG NO. AND SERIAL NO. WHEN ORDERING PARTS		REVISED BULLETIN	DATE
14.4 VOLT 1/2" SQUARE IMPACT WRENCH			July 2003
CATALOG NO.	CP8740	STARTING SERIAL NO.	A34A
		WIRING INSTRUCTION 58-01-1835	



EXAMPLE:
Component Parts (Small #) Are Included
When Ordering The Assembly (Large #).

⚠ WARNING
SWITCH POLARITY SENSITIVE
If wired incorrectly with connector block #7, switch **will be** damaged and destroyed! Refer to Service Wiring Diagram 58-01-1835.

FIG.	PART NO.	DESCRIPTION OF PART	NO.REQ.
1	05-78-0350	3mm x 15mm Self-Tapping Screw	(5)
2	05-78-0900	4mm x 20mm Pan Hd. PT T-20 Scr.	(4)
3	05-81-0409	4mm x 8mm Pan Hd. Machine Screw	(2)
4	06-65-0970	4mm x 10mm Pin	(2)
5	14-30-0580	Gearcase Assembly	(1)
6	14-50-0720	Motor Assembly (Includes item 3)	(1)
7	22-56-0195	Connector Block	(1)
8	23-66-2247	Switch Assembly	(1)
9	31-44-1405	Right Housing	(1)
10	31-44-1410	Left Housing	(1)
11	32-62-0230	Planet Gear	(2)
12	32-65-0100	Ring Gear Assembly	(1)
13	34-40-0960	Rubber Ring	(1)
14	38-50-0930	Middle Shaft Assembly	(1)
15	42-06-0485	Output Shaft Assembly (Incl. 21 & 22)	(1)
16	45-24-0520	Forward/Reverse Lever	(1)
17	45-06-0760	0.8mm x 20mm Seal	(2)
18	45-88-0845	Washer	(1)
19	45-88-0955	Washer	(1)
20	12-20-1095	Service Nameplate Kit	(1)
21	34-60-1040	Retaining Ring	(1)
22	34-40-0980	O-Ring	(1)

FIG. LUBRICATION:
6 Lightly coat the pinion area of the motor assembly with Type "L" grease, No. 49-08-4170.
12 Lightly coat the inside surface of the ring gear assembly with Type "L" grease.
4,11, 14,15,19 Lightly coat the surfaces of the pins, planet gears, middle shaft assembly, output shaft assembly and washer with Type "L" grease.

MILWAUKEE ELECTRIC TOOL CORPORATION
13135 W. LISBON RD., BROOKFIELD, WI 53005
Drwg. 2